

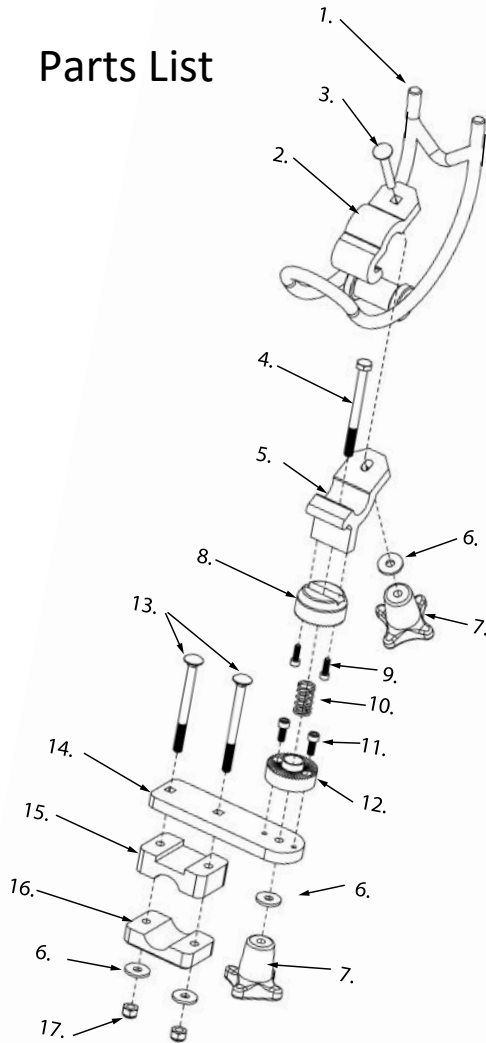

Instructions For R-500 Rail Mount Rod Holder.

Parts List



#	Description	Quantity	Size	Part Number
1	Single Rod Holder	1		Y-200-01
2.	Pivot Cap	1		Y-200-02
3.	Carriage Bolt	1	1/4" x 1-3/4" Stainless	Z-123-76
4.	Rod Holder Head Mounting Bolt	1	1/4" x 3" Stainless	Z-123-77
5.	Pivot Cradle	1		Y-200-03
6.	Flat Washer	8	1/4" x 3/4" Stainless	Z-123-68
7.	Knob	8	1/4"-20	Y-200-04
8.	Pivot Cradle Teeth	1		Y-200-05
9.	Cradle Teeth Mounting Bolts	2	8-32 x 1/2" Cap Screw Stainless	Z-123-78
10.	Spring	3		Y-200-06

11.	Cap Head Bolts	4	10-24 x 1" Stainless	Z-123-69
12.	Male Composite Teeth	2		Y-300-05
13.	Carriage Bolts	2	¼" x 3-1/2"	Z-123-97
14.	Horizontal Support	1		Y-500-01
15.	Upper Mounting Block	1		Y-500-02
16.	Lower Mounting Block	1		Y-500-03
17.	Stainless Ny-Loc Nut	2	¼"-20 Ny-Loc Nut	Z-123-96

The R-500 Rail Mount Rod Holder will fit 3/4" to 1-1/2" round or square tubing.

1. Use configuration in (Image 1) for ¾" to 1" square tubing.
2. Use configuration in (Image 2) for ¾" to 1-1/2" Round tubing.

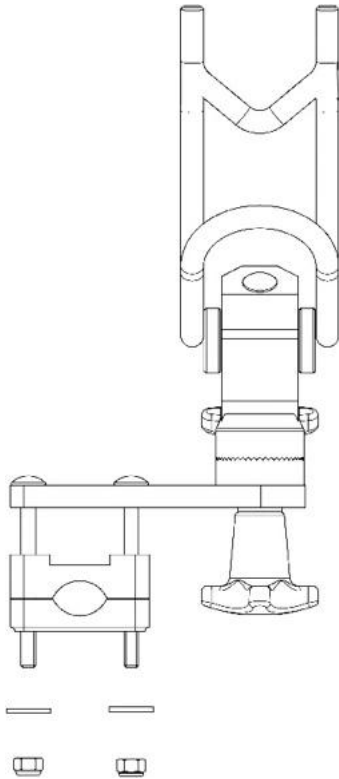

(Image 1)

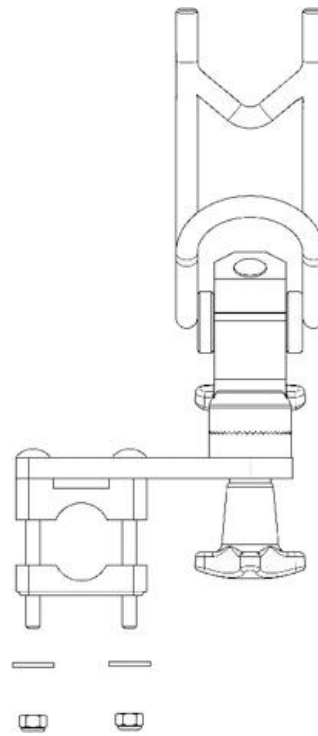

(Image 2)

3. Use configuration in (Image 3) for 1-1/16" to 1-1/2 "square tubing.

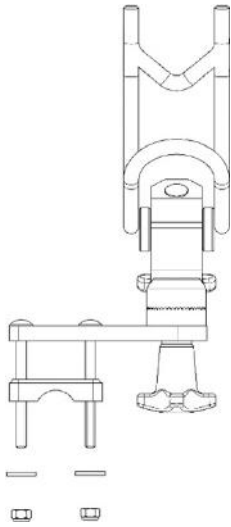

(Image 3)

WARRANTY

Millennium Outdoors, LLC Warrants its products against defects in material and workmanship with proper use and storage for a period of 1 year from the date of purchase. Proof of purchase must be presented for any warranty claim. In event the product is found to be defective within the warranty period, Millennium Outdoors, LLC only obligation and your exclusive remedy shall be replacement or repair of any defective parts at our discretion. To obtain warranty service, please contact Millennium Outdoors, LLC customer service at (601) 932-5832. Exclusions to this warranty include seat fabric, paint, plastic, webbing and/or defects caused by operator misuse and/or abuse. Limitations to liability include the forgoing warranty is made in lieu of all other warranties, expressed or implied and Millennium Outdoors, LLC disclaims any implied warranty or merchantability and fitness. Millennium Outdoors, LLC shall not be liable for any damages direct, consequential or incidental arising out of the use or inability of this product.



Millennium Outdoors, LLC 201 Fairmont Plaza Pearl, MS 39208
Phone 601-932-5832 Fax 601-932-0068
Millenniummarine.com

